

DALI 2 standard dimmers at 12 / 48 Vdc with 1 / 2 - channels

Codes: EK-GD2-DL-1-LV, EK-GD2-DL-2-LV



Datasheet STEKGD2DL12LV_EN

DALI 2 bus dimmer with 12/48 Vdc voltage supply and 1 or 2 channels, with brightness of LED sources control and dimmable in PWM modulation.



Description

The ekinex dimmers DALI 2 standard with 1 / 2-channels EK-GD2-DL-1-LV and EK-GD2-DL-2-LV allow brightness control of LED loads from 12 to 48 Vdc in constant voltage, dimmable in PWM modulation.

- The 1 CH model is DALI DT6 only and equipped with a local control device (N.O. button), connected directly to the dedicated input, with stand-alone or status update function on the DALI bus.
- the 2 CH model can be configured with a single DT6 output channel, 2 single DT6 channels or a single channel in TW DALI DT8 mode.

DT6 / DT8 setting for EK-GD2-DL-2-LV model is done via local selector switch. The devices have an integrated bus communication module DALI 2 certified.



Warning! Dimmers require the use of a power supply in accordance with EN 61347-2-13, such as the Mean Well mod. HLG-480H-24A.

Main functional characteristics

- Memory function configurable via DALI bus: it stores the last brightness level, in case of power failure
- Soft switching on and off
- Brightness adjustment to full power off (dim-to-dark)
- Min. brightness level: 0.1% (1% with push for 1 CH)
- DALI-settable dimming curve: linear/logarithmic for 1CH, 2 CH, linear/quadratic/exponential for 4 CH
- On and off times settable via DALI
- Control inputs: N.O. push button (for EK-GD2-DL-1-LV only), DALI
- Optimized output curve
- Button for mode change and / or DT6 / DT8 selection (depending on the device version)
- Status LED (switch to stand-by after 1 min.)



Note: the 1-CH device factory default values are: automatic detection of the local command set to N.O. pushbutton and minimum dimming value set to 1%.

Technical data

Inputs

- Input (constant voltage): 12 / 48 Vdc
- Supply voltage: min: 10.8 Vdc .. max: 52.8 Vdc
- Power absorbed while awaiting command: <500 mW (for EK-GD2-DL-1-LV only)
- DALI 2 bus input compliant with IEC 62386

Outputs

- Output voltage PWM 12 / 48 Vdc
- Output current: from 0 A to 10 A for EK-GD2-DL-1-LV, 5A on each channel for EK-GD2-DL-2-LV
- Rated power @12V: 120 W
- Rated power @24V: 240 W
- Rated power @48V: 480 W
- Command supply current (EK-GD2-DL-1-LV only): 0.5 mA (for 1-10V)
- Command required max. current (EK-GD2-DL-1-LV only): 0.1 mA (for 0-10V)



Note: values for output current and nominal power have to be intended as maximum values, depending on the ventilation conditions. The reported values are measured with a room temperature of 40 °C

Dimming

- "Flicker-free" PWM modulation: 2000Hz f
- PWM resolution: 16 bit
- PWM dimming range: 0.1-100% for EK-GD2-DL-1-LV, 1-100% for EK-GD2-DL-2-LV

Environmental conditions and other characteristics

- Operating temperature: -20 °C ... + 40 °C
- Storage temperature: - 40 °C ... + 60 °C
- Transport temperature: - 40 °C ... + 60 °C
- Maximum case temperature (t_c): 80 °C
- Relative humidity: 93% non-condensing
- Protection degree IP10 (device installed)
- Wiring: 1.5 mm² solid – 1.0 mm² stranded, 16-17 AWG
- Stripping: 5.0 - 6.0 mm
- Housing in plastic material
- Device suitable for installation in flush-mounting wall boxes

- Safety class II
- Weight 37 g
- Dimensions (LxHxP): 53 x 61 x 29 mm

Protections

The device is equipped with the following protections:

- OVP Over voltage protection¹
- RVP Reverse polarity protection¹
- OCP Open circuit protection

1) Control logic protection only

Control, signaling and connection elements

The devices are equipped with screw terminals for connecting the 12 / 48 Vdc input power supply (1), the output loads (3) and the DALI bus (2). The EK-GD2-DL-1-LV model is equipped with 2 poles for local control (5).

Both models have internal status LEDs (4a) and a feedback button (4b) which, in the EK-GD2-DL-2-LV model, also allows the selection of DALI DT6 / DT8 mode.

The meaning of the status LED for EK-GD2-DL-1-LV and EK-GD2-DL-2-LV devices is as follows:

- Green steady on: normal operation and DALI line present;
- Green flashing: no DALI line;
- Flashing red: generic output error.

The button (4b) for EK-GD2-DL-1-LV activates the feedback function, while for EK-GD2-DL-2-LV it allows the selection of DT6 (1 or 2 channels) or DT8 Tunable White.

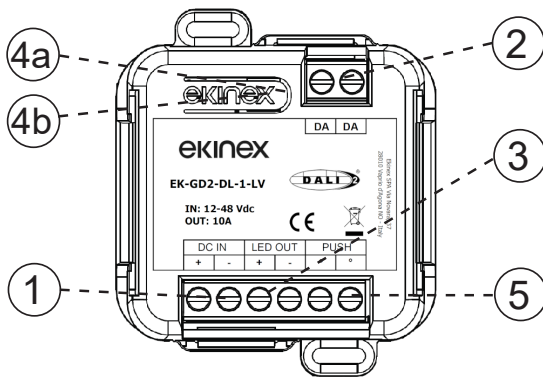

EK-GD2-DL-1-LV

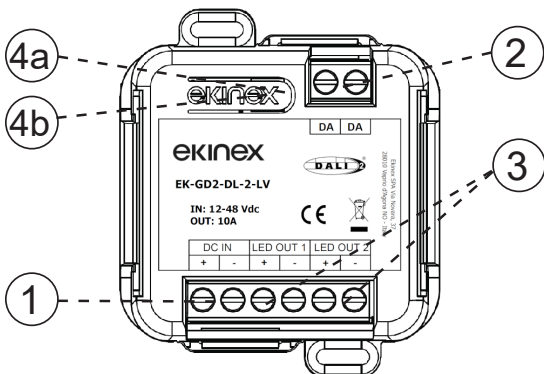

EK-GD2-DL-2-LV

| Nr. | Label | Connection |
|-------|---------------|-------------------------------------|
| 1 | DC IN (+) | DC (+) input |
| | DC IN (-) | DC (-) input |
| 2 | DA | DALI pole 1 |
| | DA | DALI pole 2 |
| 3 | LED OUT x (+) | Output x (+) |
| | LED OUT x (-) | Output x (-) |
| 4a | - | Status internal LED |
| 4b | - | Feedback or DT6 / DT8 selector (**) |
| 5 (*) | PUSH | N.O. pushbutton, pole 1 |
| | PUSH | N.O. pushbutton, pole 2 |

(*) EK-GD2-DL-1-LV only

(**) EK-GD2-DL-2-LV only

Accessory for 1 CH and 2 CH models

Rail-mounting support

The devices EK-GD2-DL-1-LV and EK-GD2-DL-2-LV can be mounted on 35 mm rail (according to EN 60715) with the plastic support included in the delivery.

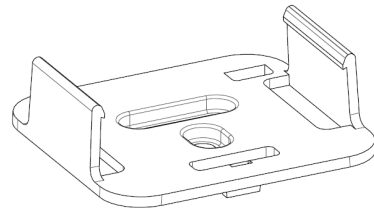

Mounting

The devices have degree of protection IP10, and are therefore suitable for use in dry interior rooms. The 1 CH and 2 CH models are suitable for installation in wall-mounting boxes. The plastic support allows mounting on a profile rail according to EN 60715 inside electrical distribution panels and cabinets.

Before removing the device, be sure that inputs, outputs, and the DC power supply have been disconnected.

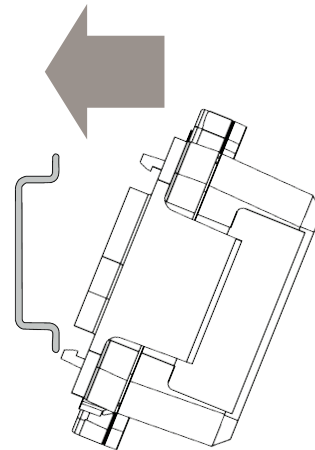



Note. When mounting the device in boards and cabinets it shall be provided the necessary ventilation so that the temperature can be kept within the operating range of the device.

Insert the mounting support in the appropriate shaped profile of the back side of the device, then hook the teeth to the profile guide starting from the bottom. Finally, push the upper part towards the guide for final coupling.

Setup and installation

The steps for installing the device are as follows:

- connect the loads to the “LED OUT” output terminals of the device;
- for the EK-GD2-DL-1-LV model, connect the local command to the “PUSH” input if you want to use the “stand-alone” mode;
- connect the DALI bus to the related DA terminal blocks;
- connect the 12/48 Vdc power supply to the terminal blocks “DC IN” of the device.

DALI bus line and command connection

The connection to the DALI bus network and the local commands is done via the screw terminal, located on the front of the device in the upper part.

For the EK-GD2-DL-1-LV device, the length of the connection cables between the local commands (if available) and the product must be less than 10m; the cables must be correctly dimensioned and they should be isolated from every wiring or parts at voltage not SELV. Use double insulated shielded and twisted cables.

The length and type of the connection cables to the DALI bus must be compliant with the protocol specification and the present regulations and they should be isolated from every wiring or parts at voltage not SELV. Use double insulated shielded and twisted cables.

INSTALLATION TECHNICAL NOTES

- Installation and maintenance must be performed only if the power supply has been turned off.
- Installation and maintenance must only be performed by qualified personnel in compliance with current regulations.
- The product must be installed inside an electrical panel protected against overvoltages.
- The product must be installed in a vertical position with the front / label facing the front or in a horizontal position with the front / label facing upwards. Other product installation positions are not allowed. The bottom position with the front panel / label facing down is not allowed.
- Keep separated the circuits at 230V and the circuits not SELV from circuits to low voltage (SELV) and from any connection with this product. It is absolutely forbidden to connect, for any reason whatsoever, directly or indirectly, the 230V mains voltage to the bus or to other parts of the circuit.



All the devices and the control signal connected to the DALI bus and to the local command (where available) must be SELV (the devices connected must be SELV or supply a SELV signal).

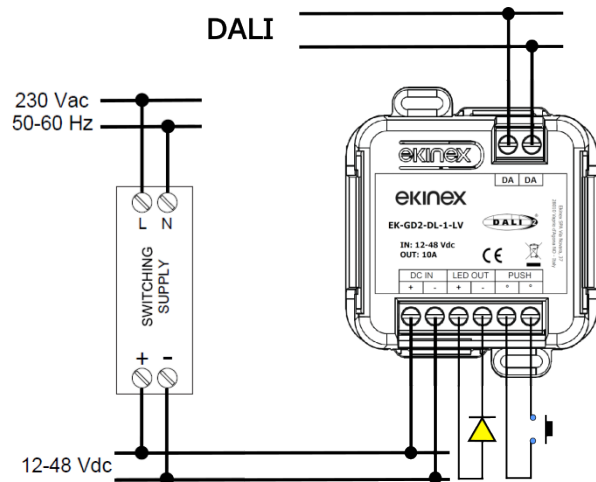

Installation scheme for EK-GD2-DL-1-LV

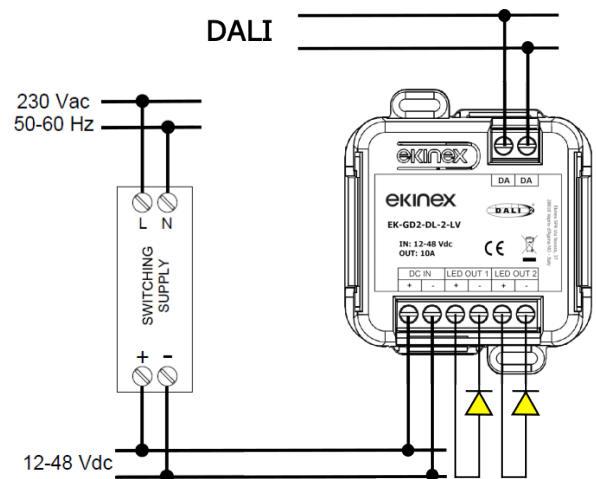

Installation scheme for EK-GD2-DL-2-LV

All the devices and the control signal connected to the DALI bus and to the local command (where available) must be SELV (the devices connected must be SELV or supply a SELV signal).

Characteristics of the DALI terminal block

- Screw tightening of the conductors
- Command and bus wiring: 1.5 mm² solid – 1.0 mm² stranded – 16 - 17 AWG
- Conductor stripping recommended: 5.0 - 6.0 mm
- Maximum length of the connection between dimmer-driver and control device < 10 m
- Length of bus connection cables < 10 m

Connection of power supply and LEDs

For the power supply use SELV power suppliers with limited current, short circuit protection only and the power must be correctly dimensioned. In case of usage of a power supplier with ground terminals, all points of the protective earth (PE = Protection Earth) must be connected to a valid and certified protection earth.

The connection cables between the power source “low voltage” and the product must be correctly dimensioned and they should be isolated from every wiring or parts at not-SELV voltage. Use double insulated cables.

The power supply must be dimensioned according to the load connected to the device. If the power supply is oversized with respect to the maximum absorbed current, then insert a protection against over-current between the power supply and the device.

Characteristics of the supply and LEDs terminal block

- Screw tightening of the conductors
- Power and LEDs wiring: 1.5 mm² solid – 1.0 mm² stranded – 16 - 17 AWG
- Power and LEDs stripping recommended approx.: 5.0 - 6.0 mm
- Max torque 0.5 Nm

Outputs

The length of the connection cables between the product and the LED modules must be less than 10 m; the cables must be dimensioned correctly and must be isolated from any wiring or parts with non-SELV voltage. Use double insulated shielded and twisted cables.

If you want to use connection cables between the product and the LED modules over 10m, the installer must ensure the proper functioning of the system. In any case, the connection between the product and the LED modules must not exceed 30 m.

Configuration and commissioning

Configuration and commissioning activities of the device must be carried out according to the design of the building automation system done by qualified planners.

For commissioning the device the following activities are required:

- make the electrical connections as indicated above;
- power up the bus;
- for EK-GD2-DL-1-LV device, it is possible to select the “stand-alone” mode through the local command (connection to the DALI bus is not necessary);
- carry out the device programming, as described below.

EK-GD2-DL-1-LV programming

At the first start-up, in case of lack of the DALI bus, the local control is active and the LED placed under the front programming key is orange. When the presence of the DALI bus is detected, control passes to it. In the absence of the DALI bus, control passes to local control by pressing the button.

Button behavior:

- Short press: on / off function;
- Long press: reverses the direction of dimming.

The device is equipped with a programming button on the front, near the DA terminal: by pressing the programming button for 5 seconds, the status LED starts flashing. Pressing the button again allows you to select the function of the device:

- Default function (orange status LED): sets the System Fail Level parameter = 100% and the Fade Time = 0.7 s), to make the device work even in the absence of a

signal on the DALI bus and immediately use the fade, otherwise the switching on and off would be immediate.

- Advanced function (blue status LED): using a DALI programmer such as USB DALI interface Tridonic, Lunatone DALI Cockpit or similar, it is possible to program the parameters System Fail Level = 100% and Fade Time = 0, according to the DALI specifications.



Note. The programming of the parameters mentioned above must be carried out only during the programming phase. If the customer has a DALI programmer / master, he can reprogram them as he wishes.

A further long press of the programming button for at least 5 seconds confirms the setting of the selected function.

The device will always work in both modes: the default or advanced programming only sets the DALI System Fail Level and Fade Time parameters without the need for a DALI programmer.



Note. If the dimmer is used together with a broadcast DALI device, depending on the implementation of the firmware, the broadcast function may prevail over the local command.

Courtesy light function (EK-GD2-DL-1-LV) only

When the output is off, a long press of the local control button for at least 0.7 s turns on the load at minimum intensity for 2 s, then starts dimming towards maximum intensity. If the button is released at this stage, the brightness level stops.

EK-GD2-DL-2-LV programming

The device is equipped with a programming button on the front, near the DA terminals, to select the DALI DT6 / DT8 configuration of the channels.

While the status LED is on, a long press of the programming button for at least 5 s allows you to enter programming mode and the LED flashes.

At this point:

- by pressing the button once, the LED lights up purple, to indicate the programming of both outputs as a single DALI DT6 channel;
- by pressing the button again, the LED lights up blue, to indicate the programming of the outputs as 2 single channels DALI DT6;
- pressing the button again will cause the yellow LED to light up, indicating that the programming of the outputs is in Tunable White (dynamic white) with 1 DALI DT8 channel;
- with a long press of at least 5 s the configuration is saved and the menu is exited;
- after 60 s without further pressing the programming key, the device exits the menu without saving the setting.

The setting of the output channels can also be done using DALI programmers. An example is shown in the next figures.



DT6 with single output channel

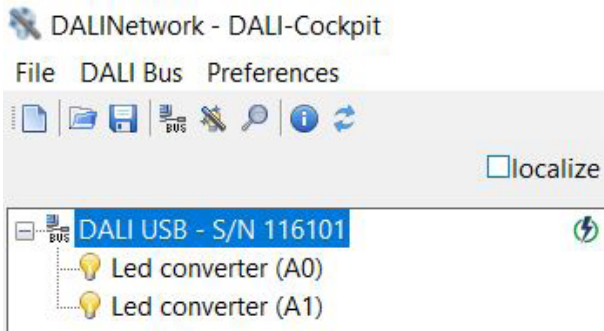

DT6 with 2 independent output channels



DT8 with single Tunable White output channel

Status LED

The meaning of the status LED under the programming button is as follows:

- Green steady on: normal operation and DALI line present
- Flashing green: no DALI line
- Flashing red: generic error on the output

If the programming button is not pressed within 1 minute, the status LED goes into standby. A short press of the programming button turns the LED back on and shows the status.

Configuration change

Subsequently, it is possible to change the device configuration and addressing using an application for parameterization, for example by downloading the ekinex CGEKBG1TP software to the PC which allows you to:

- configure the DALI system and define its parameters;
- set the DALI devices (groups, scenarios, IDs, etc.);
- test the communication on the DALI bus;
- update the device.

The software can be downloaded from the website www.ekinex.com and its use is described in the application manual of the ekinex EK-BG1-TP DALI Gateway. The software works with Microsoft Windows (7 and later).



Note. For the CGEKBG1TP configuration software to work, it may be necessary to install .NET Framework 4, which can be downloaded freely from the Microsoft website.

DALI System fail function

For each device it is possible to set the "system failure" parameter, that is the brightness level at which the LED load is set, in case of DALI bus outage.

This setting can be done using a DALI programmer such as USB DALI interface Tridonic, Lunatone DALI Cockpit or similar.

The range of brightness values is from 0 to 254 (100%).

If the value 255 (MASK) is set, the last brightness value is restored.

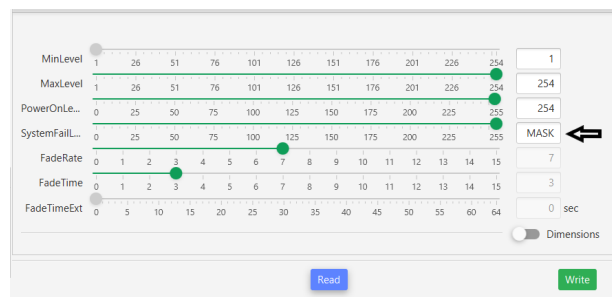

Flickering

The graph below shows the flickering limit curves across the entire frequency range, distinguishing areas with low or no visible risk to people's health (yellow area) from areas with no observable effect (green area).

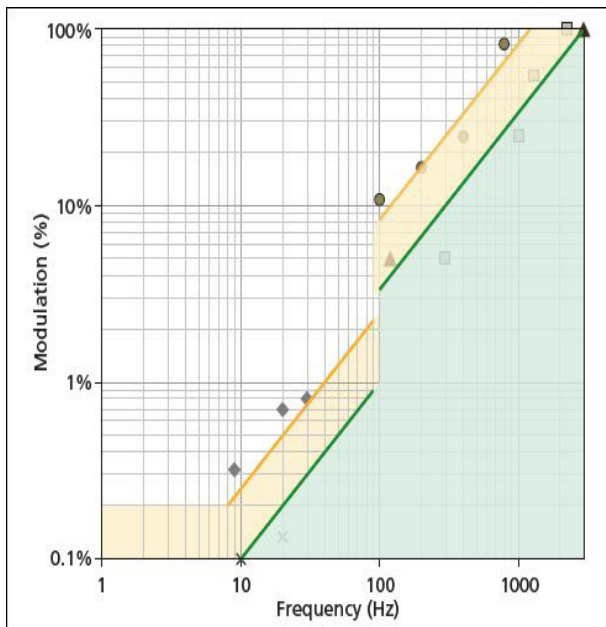

Depending on the sensitivity and frequency, these disturbances can cause damage to people's well-being. It is proven that while very high frequencies have no effect on well-being, while those below 120 Hz do. The IEEE 1789-2015 standard provides comprehensive recommendations for reducing health risk for people.

Dimensions

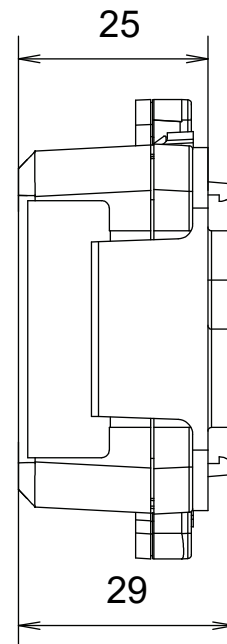
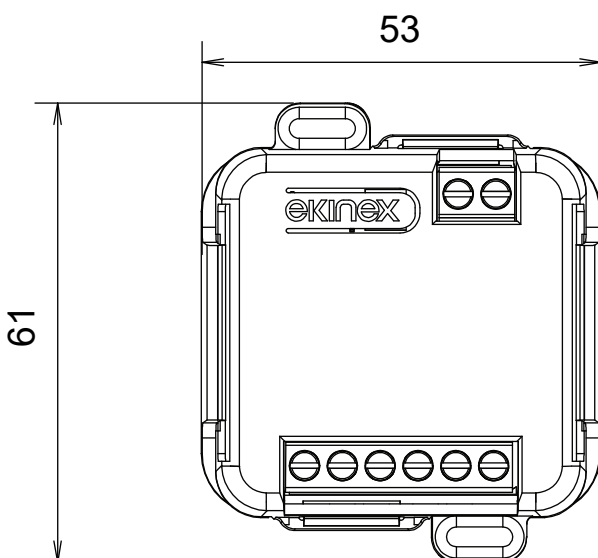

Marks

- CE: the device complies with the Electromagnetic Compatibility Directive (2014/30/EU), the Low Voltage Directive (2014/35/EU) and the RoHS III Directive (2011/65/EU).
- Reference Standards: EN 61347-1:2015, EN 61347-2-13, EN 55015:2013+A1:2015, EN 61547:2009, EN 50581:2012, IEC/EN 62386-101/102/207, IEC/EN 60929-E.2.1.

References

- IEC/EN 62386-101 - Digital addressable lighting interface, General requirements - System
- IEC/EN 62386-102 Digital addressable lighting interface, General requirements - Control gear
- IEC/EN 62386-207 Digital addressable lighting interface, Particular requirements for control gear – LED modules (device type 6).
- IEC 60929-E.2.1 Control interface for controllable ballasts - control by DC voltage - functional specification

Maintenance

The device is maintenance-free. To clean use a dry cloth. It must be avoided the use of solvents or other aggressive substances.

Disposal



At the end of its useful life the product described in this datasheet is classified as waste from electronic equipment in accordance with the European Directive 2012/19/EU (WEEE recast), and cannot be disposed together with the municipal undifferentiated solid waste.



Warning! Incorrect disposal of this product may cause serious damage to the environment and human health. Please be informed about the correct disposal procedures for waste collecting and processing provided by local authorities.

Warnings

- Installation, electrical connection, configuration and commissioning of the device can only be carried out by qualified personnel in compliance with the applicable technical standards and laws of the respective countries
- Opening the housing of the device causes the immediate end of the warranty period
- In case of tampering, the compliance with the essential requirements of the applicable directives, for which the device has been certified, is no longer guaranteed
- ekinex® defective devices must be returned to the manufacturer at the following address: Ekinex S.p.A. Via Novara 35, I-28010 Vaprio d'Agogna (NO) Italy

Other information

- The instruction sheet must be delivered to the end customer with the project documentation
- For further information on the product, please contact the ekinex® technical support at the e-mail address: support@ekinex.com or visit the website www.ekinex.com
- Each ekinex® device has a unique serial number on the label. The serial number can be used by installers or system integrators for documentation purposes and has to be added in each communication addressed to the EKINEX technical support in case of malfunctioning of the device
- DALI, DALI2 and their logos are registered trademarks of the Digital Illumination Interface Alliance (DiiA).

© EKINEX S.p.A. The company reserves the right to make changes to this documentation without notice.